

LOW PROFILE HOPPER [A298/A299] FOR MKX/X100 AND MKX/X130 SERIES AUGER MODELS ASSEMBLY & MAINTENANCE



Read and understand the safety information in the auger manual before proceeding.



Read and understand the instructions in this manual before attempting to install this product.



Refer to the auger manual for operation instructions.

PRE-INSTALLATION INSTRUCTIONS

1. Lower the auger to full down position, and disconnect the tractor from the auger (PTO shaft, hydraulic lines, and hitch).
2. Chock the auger wheels to prevent rolling.
3. Lower the swing hopper fully to the ground.

LOW PROFILE HOPPER INSTALLATION

Note: *The gearbox has been filled at the factory (half full) with EP90 gear oil. Before further assembly, check oil level to make certain the gearbox is half full as required. Add oil if necessary. Do not use grease.*

1. Attach the transition to the lower (for A298) or upper (A299) holes in the intake hopper with two 5/8" x 1-1/2" bolts and 5/8" locknuts (see Figure 1). Do not over-tighten; tighten snug only as these bolts act as pivot points.
2. Clean dirt and paint from inside u-joint and flight shaft end, then insert Woodruff key.
3. Raise and support hopper tube spout head on a stand about 50" high.
4. Open the access door on the transition, then bring the tube and transition together guiding the flight shaft into the u-joint (see Figure 2).

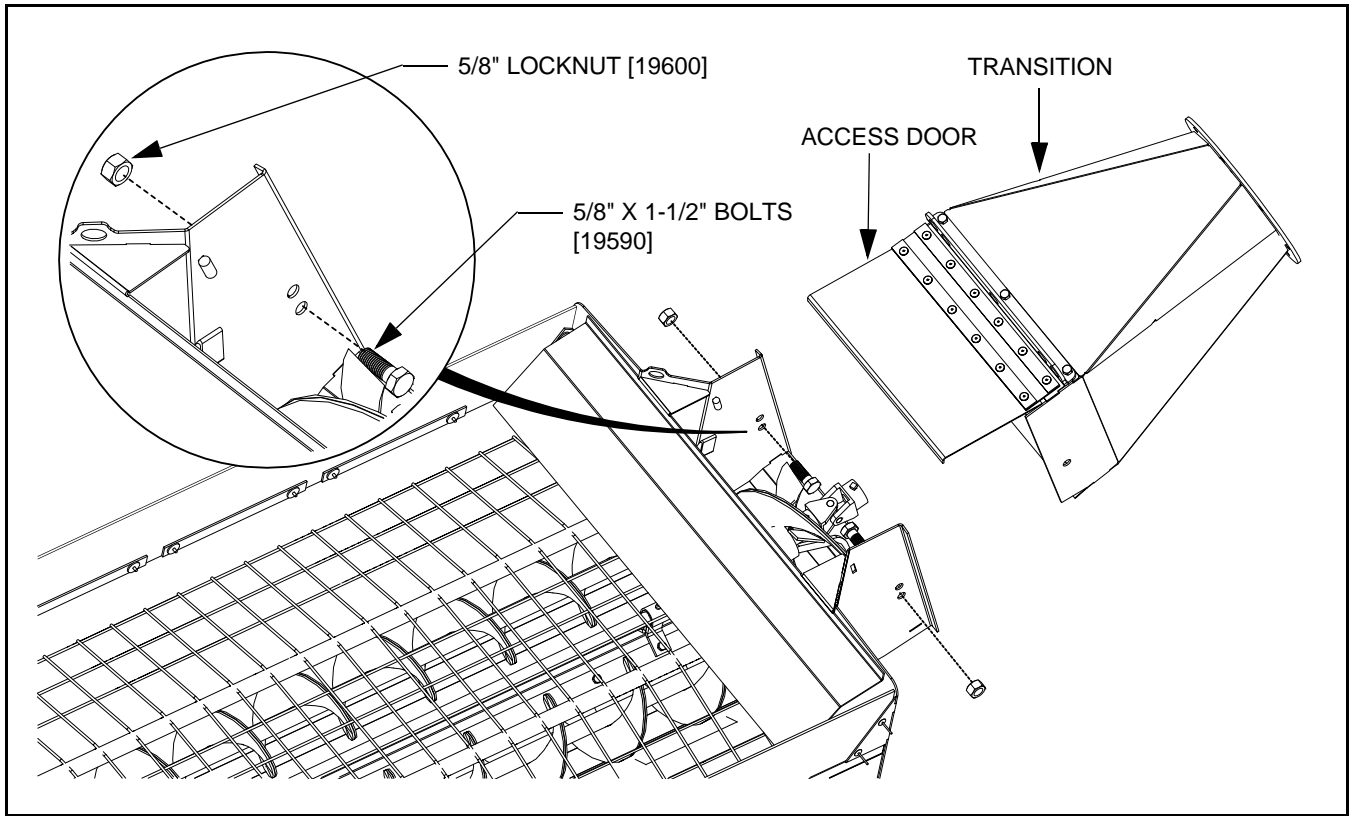

Figure 1

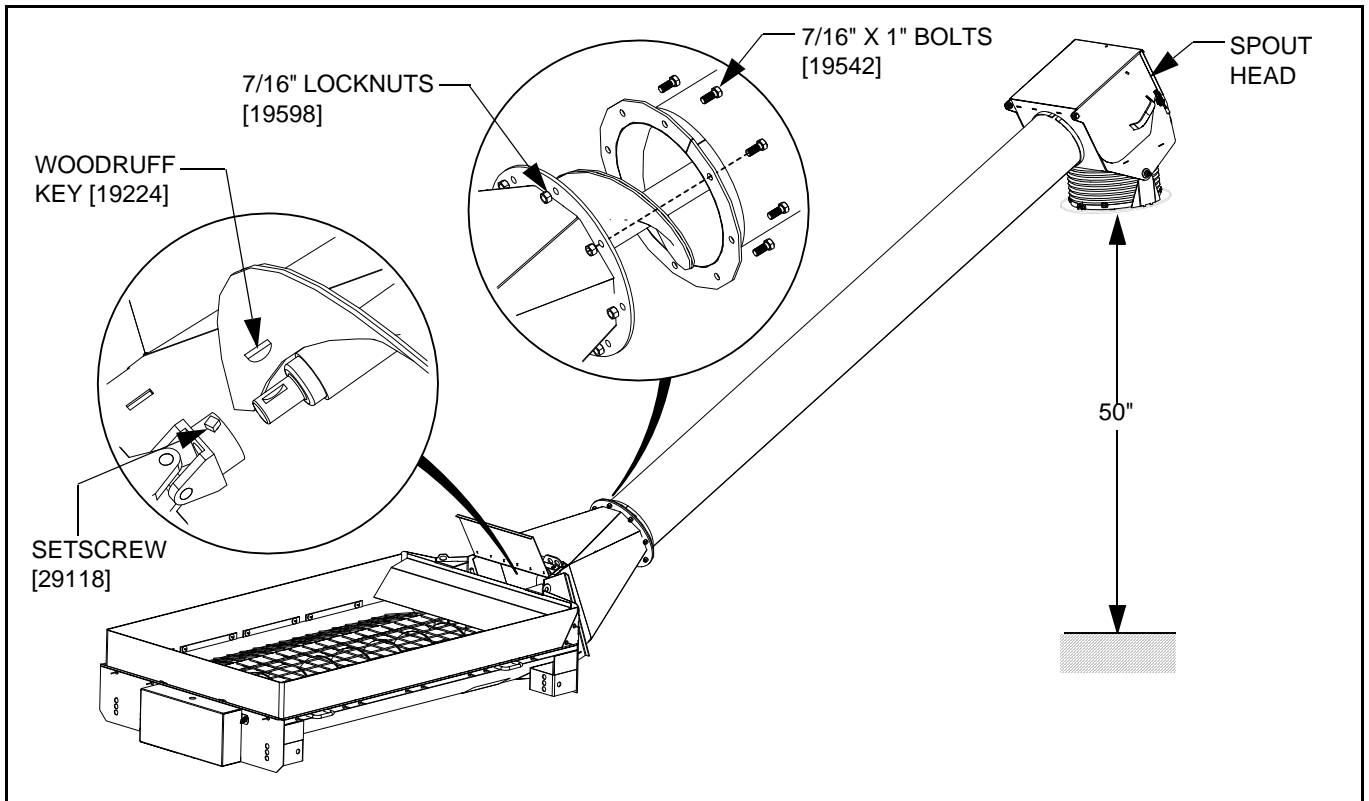

Figure 2

5. Secure tube to pivot-connector on hopper with eight (for A298) or twelve (for A299) 7/16" x 1" bolts and 7/16" locknuts.
6. Tighten set screws on u-joints, then close and secure the access door.
7. Attach the four solid wheels to the four hopper corners with the wheel axles and snap pins. There are three height settings (see Figure 3) that can be used according to preference.

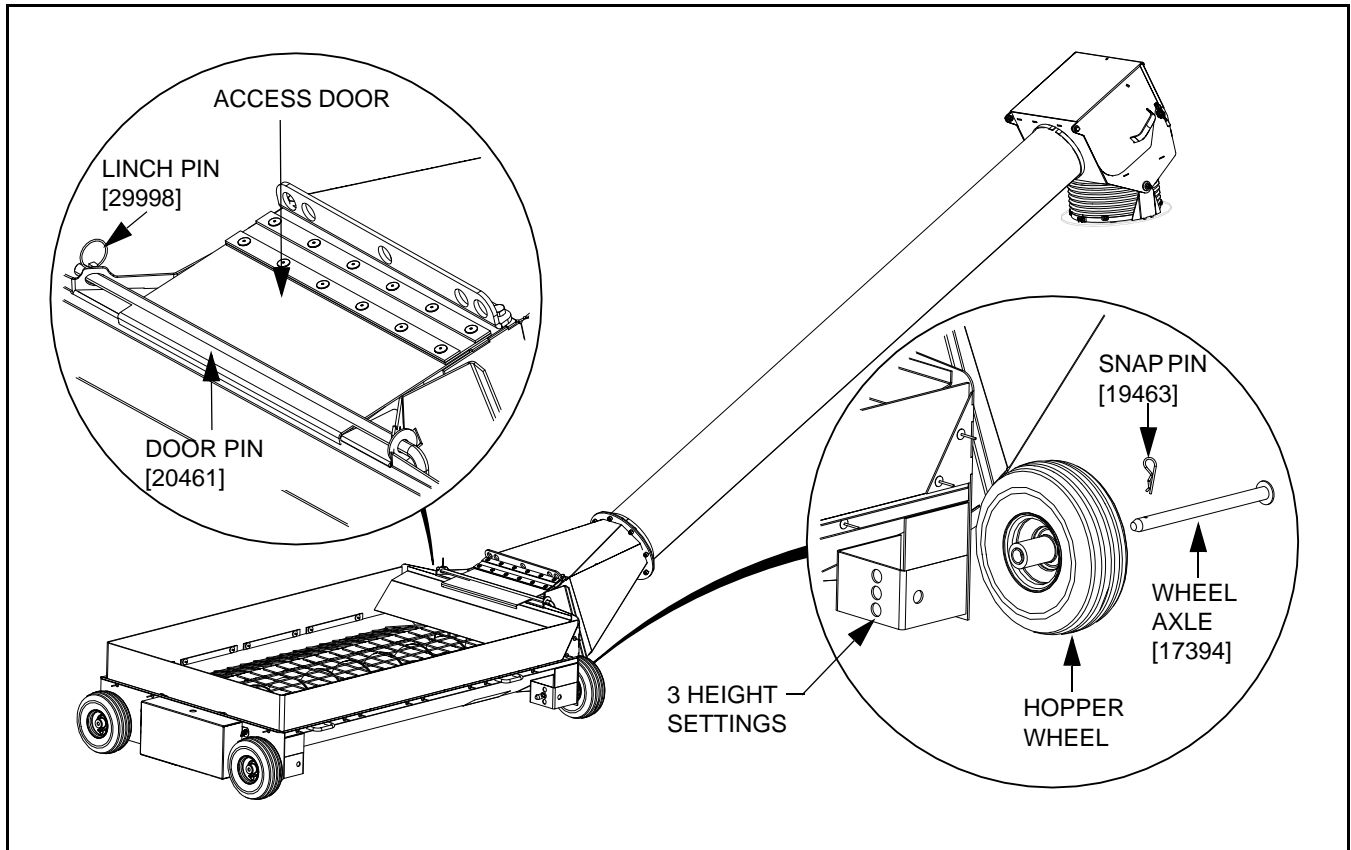

Figure 3

8. To connect the intake hopper to the auger boot, the spout head door must be first opened (see Figure 4). To do so, open the latch and rotate the spout door open, so that it lies down on the top of the swing tube.
9. Check that the u-joint spline and splined shaft on the lower gearbox are clean, then apply a light film of grease on the splined shaft.
10. Install a rim washer on the top shaft of the lower gearbox.
11. Shift the position of the hopper so that the spout head is supported above the boot, centered on the shaft of the gearbox.
12. Lower spout head onto the boot while guiding the splined universal joint onto the splined gearbox shaft. Once positioned, the spout head base should be resting flat on the boot surface.
13. Install spout head spacers, followed by spout-head retainers, using eight 3/8" x 3/4" bolts (see Figure 4).

14. Lubricate the universal joint and then close and secure the spout head service cover.

Important: *Always keep the spout head service cover closed and secured during operation.*

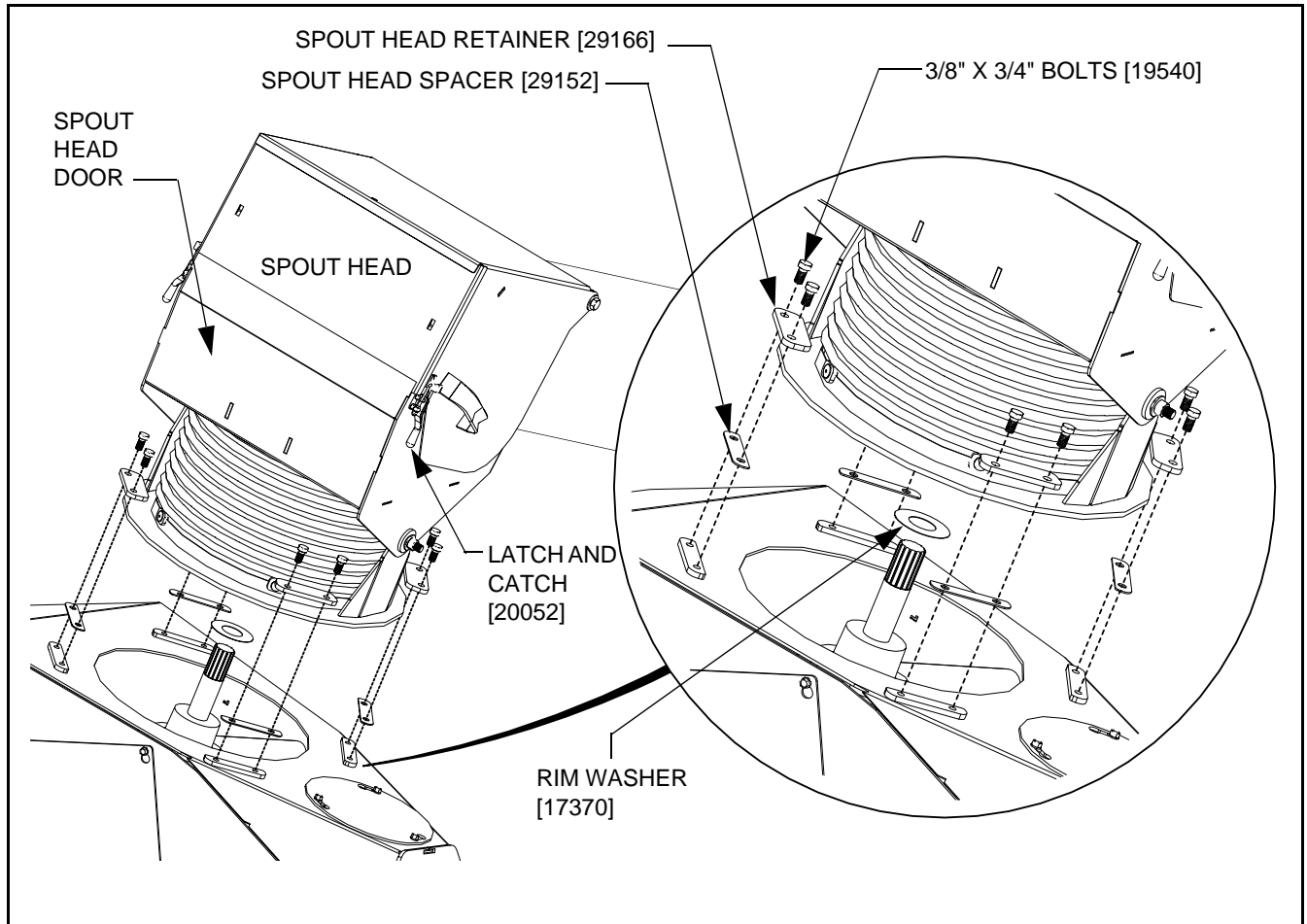

Figure 4

MAINTENANCE OF LOW PROFILE HOPPER

Before performing maintenance, shut off tractor and remove the key. If this is not possible, disconnect PTO driveline from tractor.

Frequent:

Open the access door - then grease the four bushings and two u-joints. Close the access door, then slide in the door pin and secure with linch pin (see Figure 3).

Occasional:

1. Check and adjust the hopper drive chain.
2. Lubricate the hopper drive chain.

Note: *For all other instructions, see Operator's Manual.*