

## MK130 REVERSING KIT INSTALLATION, OPERATION, & SAFETY

We recommend that two or more people be present for this procedure.

### AUGER PREPARATION FOR KIT INSTALLATION

1. Lower auger to full down position and remove tractor from auger.
2. Chock auger wheels to prevent rolling.
3. Lower swing hopper fully to the ground.
4. Support auger intake end securely with front end loader and strong sling or chain, or with block and tackle.
5. Remove swing hopper from auger boot.
6. Remove PTO driveline from auger.
7. Remove sprocket shield from boot.
8. Remove drive chain from the front of the boot.

### REVERSING KIT INSTALLATION

1. Knock steel plugs out of holes X and Y (Figure 1), using a punch and a hammer.
2. Install reverser base with two 1/2" x 1-1/4" bolts, washers and locknuts. Do not tighten until Step 6 (Figure 2).

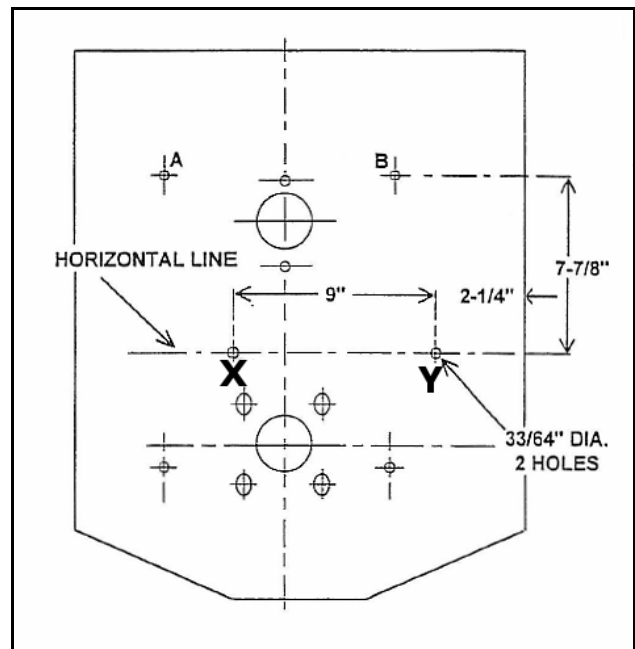

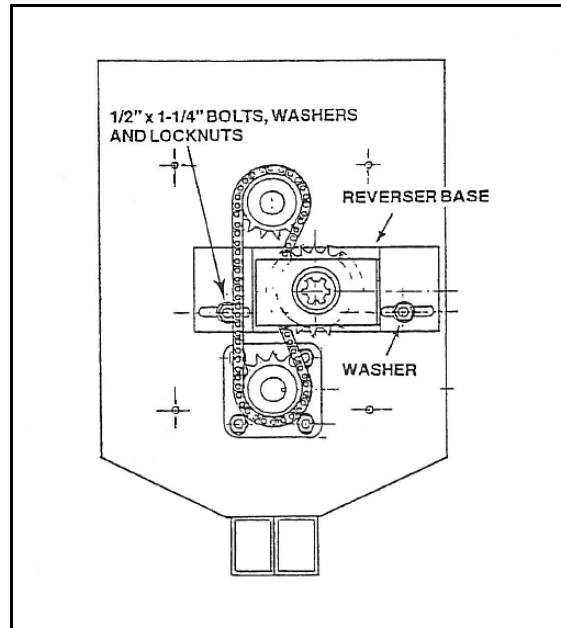

**Figure 2**

3. Install a half-link on roller chain and place chain over upper and lower sprockets, passing it through the reverser base.
4. Install connector link.
5. Push the reverser base against the chain as tight as possible and tighten the two 1/2" x 1-1/4" bolts.

**Note:** *It may be necessary to loosen the lower bearing and raise the lower sprocket to get proper chain wrap on the reverser sprocket.*

6. Install splined coupler on flight shaft using a 3/8" x 1-3/4" square key and a 3/8" roll pin.

<b>CAUTION</b>	
	<p>Protect your eyes when tapping in the roll pin.</p>

7. Install new sprocket shield using four 5/16" x 3/4" bolts. Discard old sprocket shield (Figure 3).

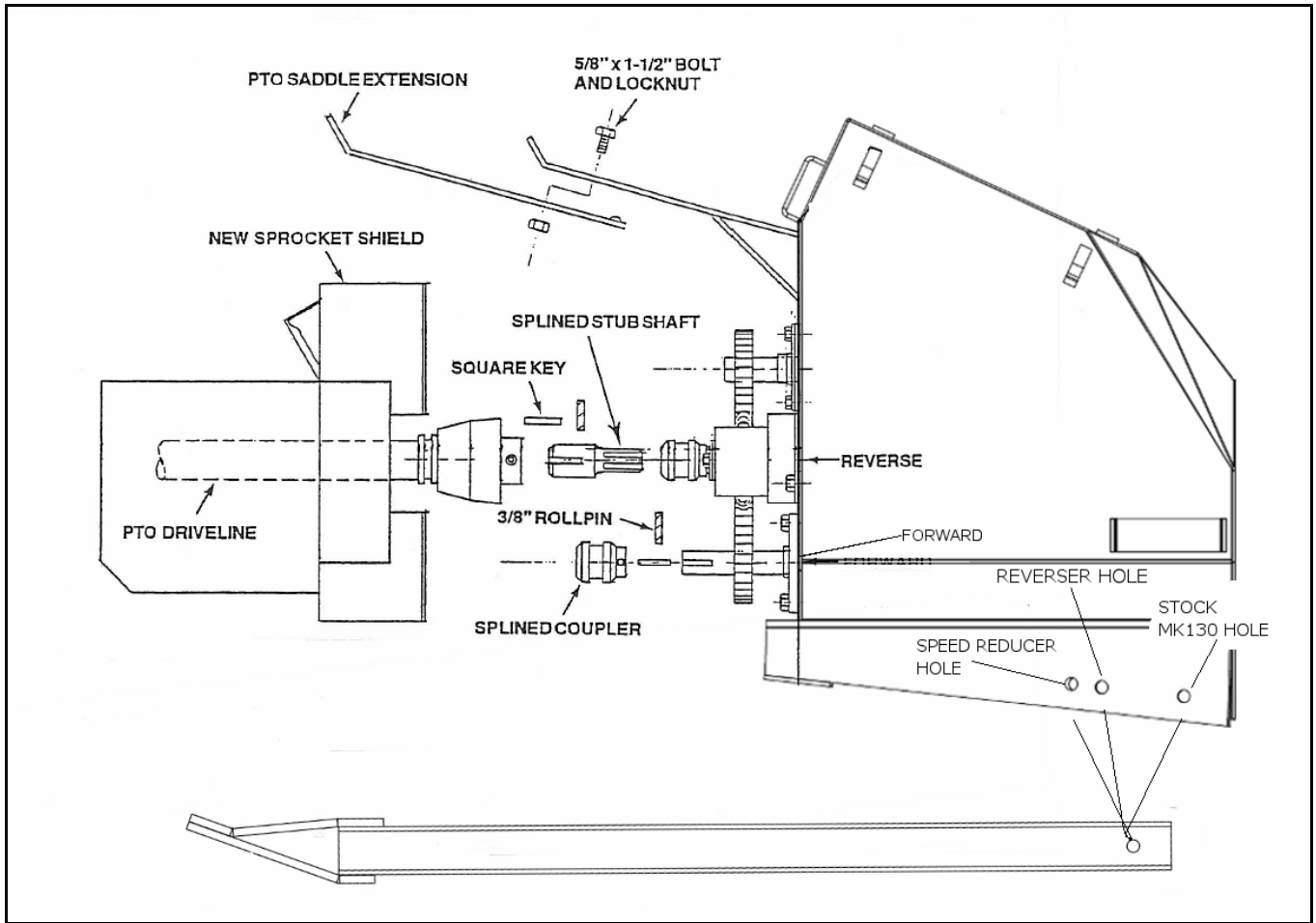

**Figure 3**

8. Attach PTO saddle extension to existing bracket with one 5/8" x 1-1/2" bolt and locknut.
9. Install a splined stub shaft on the PTO driveline using a 3/8" x 1-3/4" square key and 3/8" roll pin. Use a thread locking compound on set screws and install and tighten them securely.
10. Install jack extension with jack extension bolt and 5/8" locknut provided as shown in Figure 4.

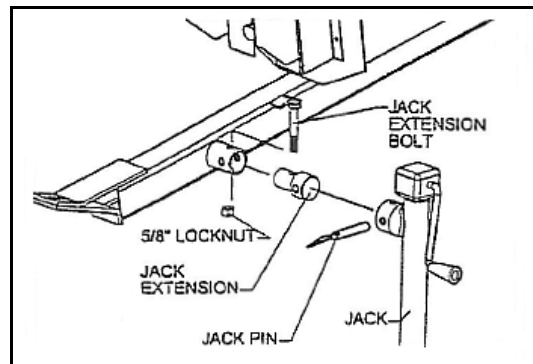

**Figure 4**

# REVERSER OPERATING & SAFETY INSTRUCTIONS

Additional to instructions in operation manual. Read and understand all instructions before operating auger.

CAUTION	
	<p>Shut down and lock out all power before emptying boot and power before changing to forward or reverse modes.</p> <p>Ensure that PTO driveline is securely attached before operating. Keep body, hair, and clothing away from all moving parts including PTO driveline.</p> <p>Do not exceed reverse operating speed of 100 rpm. Do not exceed forward operating speed of 540 rpm.</p>

## Before Operating in the Normal Forward Mode:

1. The stub spline on the PTO driveline must be inserted into the lower spline coupler and securely locked into place.
2. Make certain the cleanout cover is secured into place on the boot before operating.

**Note:** *All safety shields must be in place before operating.*

## To Operate in the Reverse Mode:

1. Insert the stub spline on the PTO driveline into the upper spline coupler, making certain it is securely locked into place.
2. Remove cleanout cover before operating in reverse mode.
3. Operate auger slowly in reverse for a short period of time. **Do not exceed 100 rpm.**
4. When boot is nearly full, shut off and lock out power, then clean out grain from boot using a stick. Do not use hands. Repeat above procedure as needed.

**Important:** *The Reversing Kit is designed to assist in clean out of auger. **It is not designed to unplug auger.** When operating in the reverse mode, auger must be monitored to prevent boot from overfilling. Excessive back pressure will cause extensive damage to the auger which is not covered by warranty.*



**Figure 5**

*\* WESTFIELD reserves the right to update safety decals without notice. Safety decals may not be exactly as shown.*

**WESTFIELD** 

part of the Ag Growth International Inc. Group  
Box 39, Rosenort, Manitoba, Canada R0G 1W0 Ph: (866) 467-7207 Fax: (866) 768-4852  
Web: [www.grainaugers.com](http://www.grainaugers.com) E-mail: [sales@grainaugers.com](mailto:sales@grainaugers.com)

**AGI**   
AG GROWTH INTERNATIONAL